

ENROULEUR PROFURL R250 (6,5Kg)

PROFIL R250
Ech. 1:1

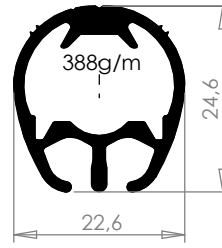

Lg Profils: 2m
(Profil bas : 2m)

PROFIL 00AL
Ech. 1:1

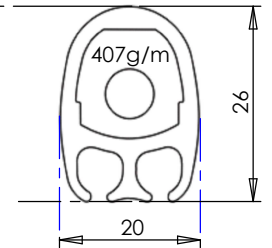

Lg Profils: 2,13m
(Profil bas : 0,61m)

Poids ensembles Profils (avec jonctions & feeder):

- R250 = (9,380 x 388) + (240+95) = 3974g

- 00AL = ((9,380+0,103) x 407) + (298+110) = 4268g

ENROULEUR HARKEN 00AL (5,9Kg)

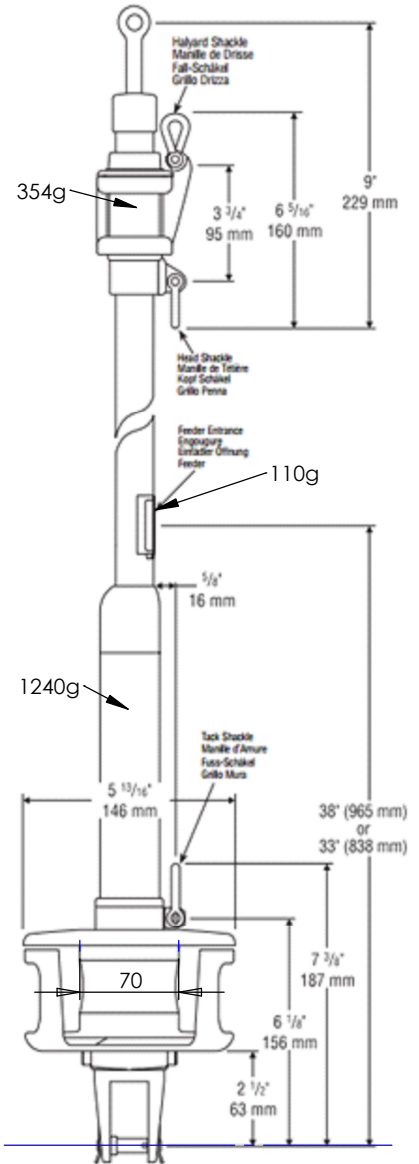
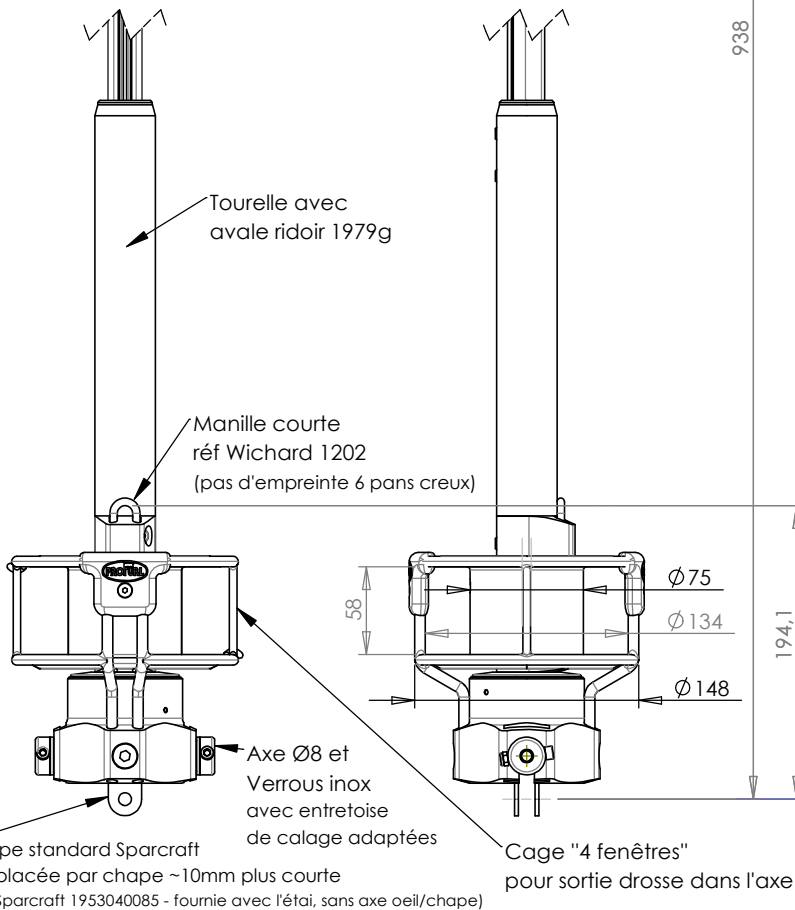
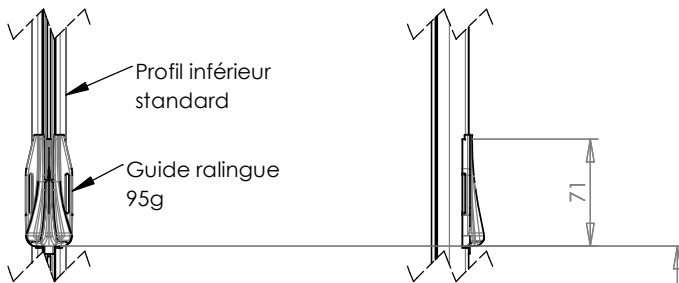
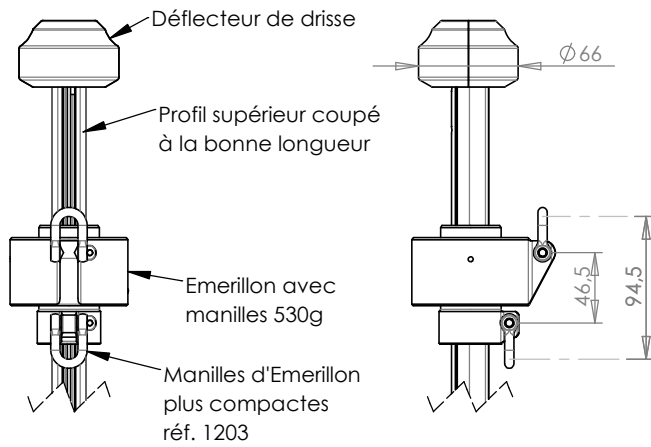

Indice



ENROULEUR PROFURL réf. R25010J80
REMPACANT LE HARKEN 00AL SUR LES J80

PAR: ST
Le: 19/01/18

ECHELLE

1/5

FORMAT
A4